

THIS DRAWING IS UNPUBLISHED. RELEASED FOR PUBLICATION, 19
 © COPYRIGHT 19 BY AMP INCORPORATED. ALL INTERNATIONAL RIGHTS RESERVED.

LOC	DIST	P	F	REVISIONS				DATE	APPD
AF	50			ZONE	LTR	DESCRIPTION			
					M	REV PER 0G3A-0238-02	26APR02	JR/PD	

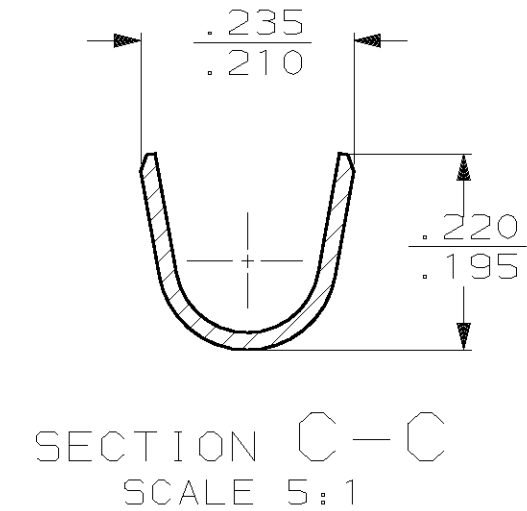
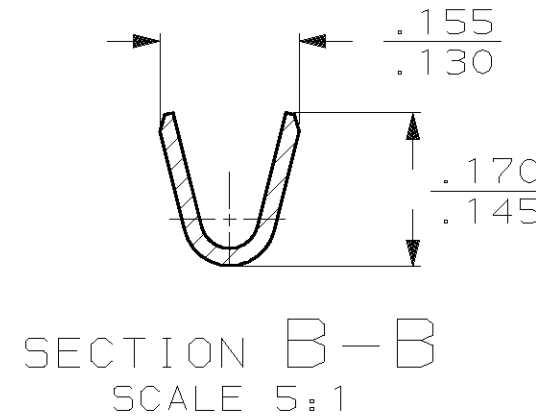
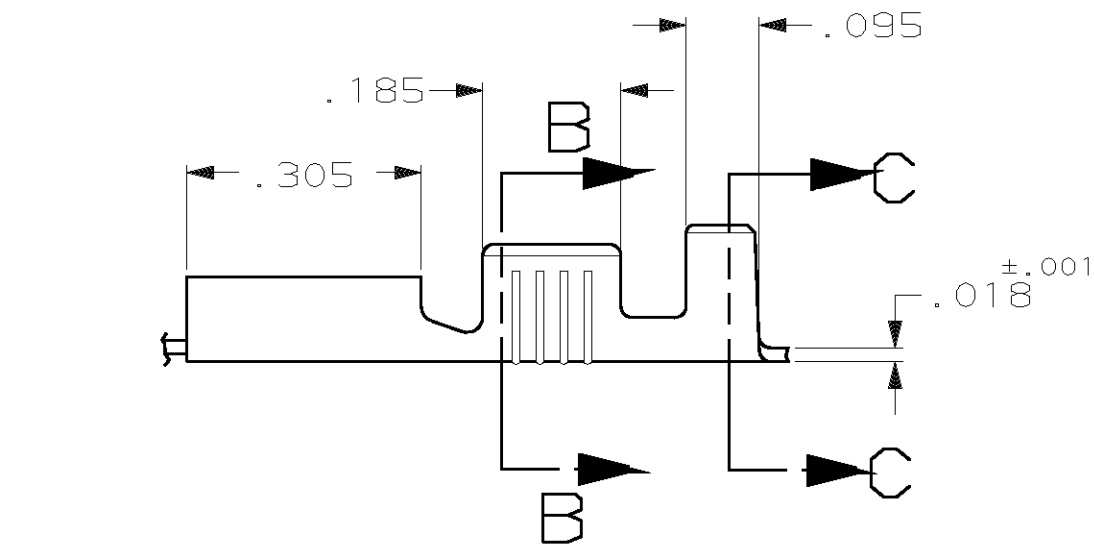
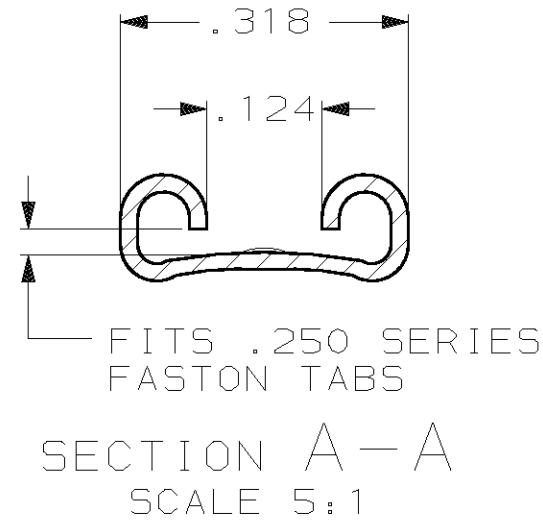
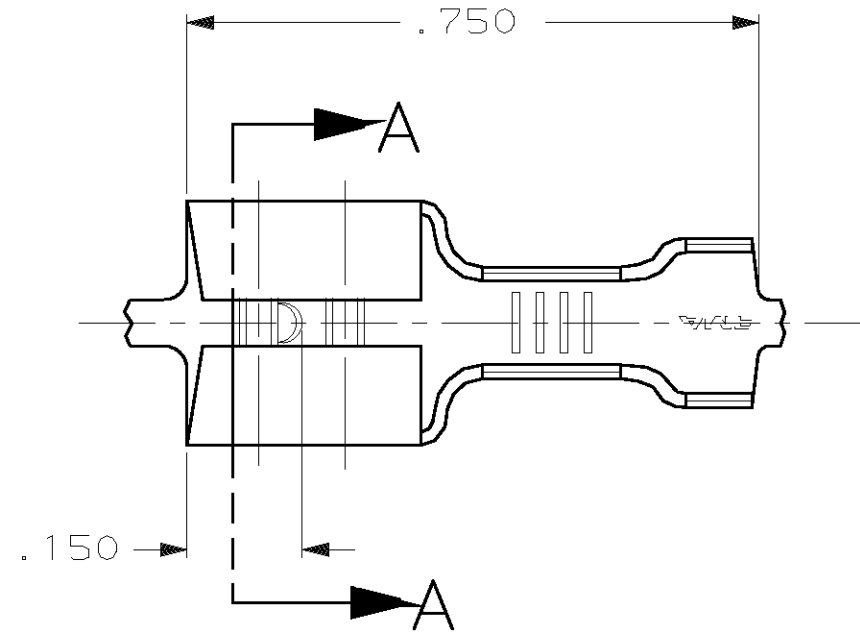

- 1 CONTINUOUS STRIP ON REELS.
- 2 MAX FIRST ENGAGEMENT FORCE, 20 LBS, USING GAGE 100505.
- 3 FEED TO BE $.840 \pm .005$.
- 4 WIRE SIZE IS #18-#14 AWG.
- 5 MATING TAB THK IS $.032 \pm .001$
- 6 INSULATION RANGE IS $.120-.170$ DIA
- 7 SPECIAL PACKAGING QUANTITY
- 8 PRELIMINARY - NOT FOR PRODUCTION

7	8	41774-1
41774		
PART NO		

DO NOT SCALE PRINT. UNLESS SPECIFIED DIMENSIONS ARE IN INCHES TOLERANCES ON: 2 PLC DEC ± - 3 PLC DEC ± .015 ANGLES ± -	DR 6/13/91	AMP AMP Incorporated Harrisburg, PA 17105-3608
	CHK 6/13/91	
	MS FEHER	
	APPD 6/13/91	
MATERIAL	APPD 6/13/91	NAME
T3 PH05 BRZ.	C MEYERS	RECEPTACLE, FASTON™
FINISH	APPD 6/13/91	.250 SERIES
TIN .000080 MIN	D REINER	SIZE
	PRODUCT SPEC	B
	APPLICATION SPEC	CAGE CODE
	WEIGHT -	00779
		DRAWING NO
		41774
		SCALE
		4:1
		SHEET
		1 OF 1